



# D6

## Street Sweeper

Ideal for all conditions  
and situations







**Innovation**  
**New technology**  
**High quality**  
**components**





City Center



Parking



Industry



Heavy industry



Extra Urban



Old Town



Circuit





PRODUCTIVITY

# Efficiency and cost reduction

It ensures the highest performance levels in every context, reducing consumption compared to the past.

# Efficiency Everywhere

## Savings in water consumption

Water is only used to cut down on dust on the external brushes.

## 12 months of use

12 months of use Ability to sweep even without using water makes it possible to also work with low outdoor temperatures.

## No sweeping limit

Possibility of collecting light, heavy and even bulky material.

## High filtering rate

Dust filter for constant and efficient filtering in all conditions.







DULEVO CONNECT

## Easy and intuitive use

Less time needed to train the operator, possibility to customise the operating methods of the vehicle.

# Smart Thinking

## Touchscreen Panel

User friendly and Easy Start functions.

## On-board diagnostics

Possibility to directly access the function diagnostics and the motor status indications from the display.

## Dulevo Telematic (Tierra)

Possibility to remotely access the vehicle diagnostics and information.

## Set-up for remote connectivity 4.0 Smart City

Two-way interface system.

## Can Bus

In/Out communication system of the sweeping functions and motor on CAN-BUS protocol.





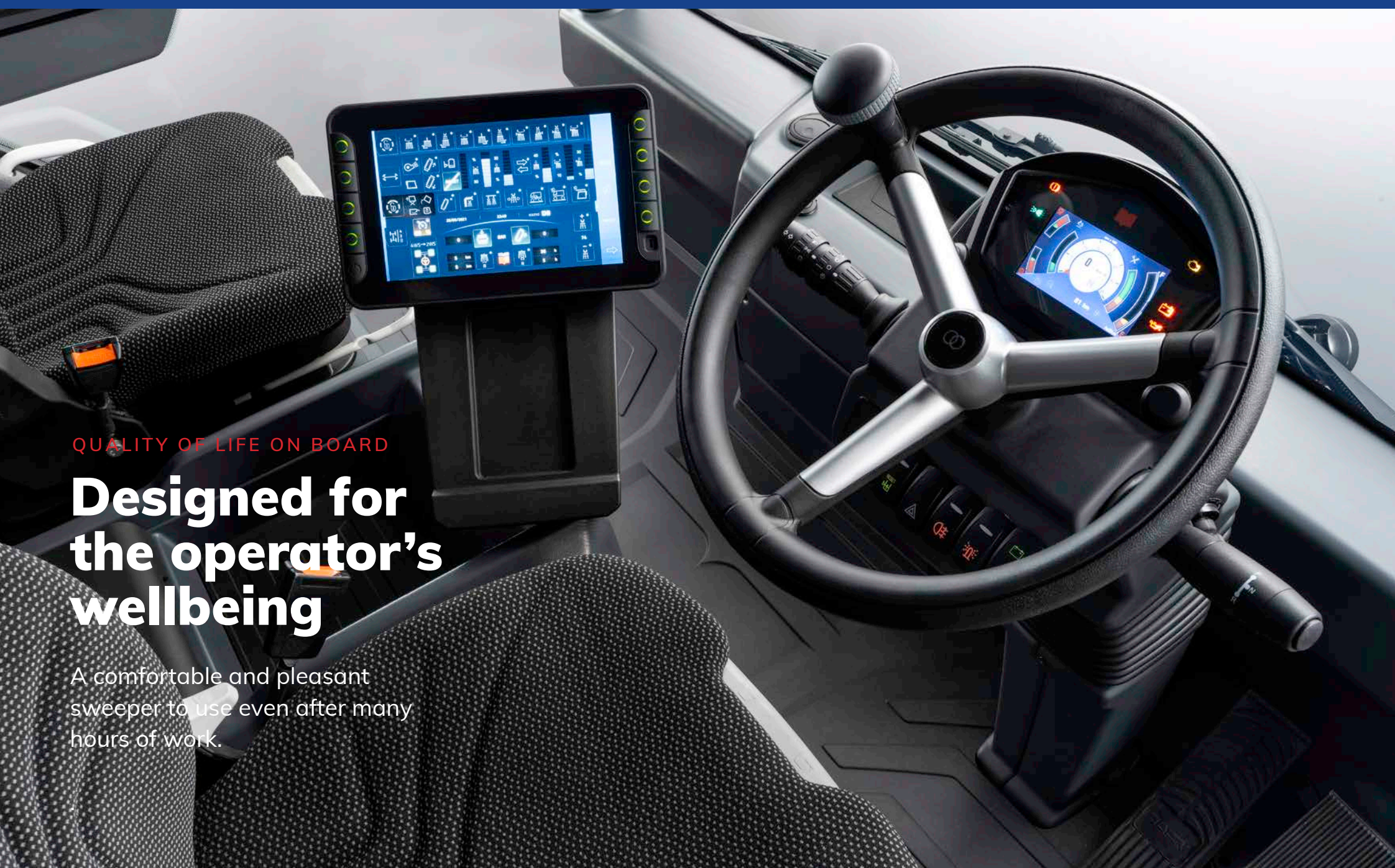

QUALITY OF LIFE ON BOARD

# Designed for the operator's wellbeing

A comfortable and pleasant sweeper to use even after many hours of work.



# Designed for People

## Greater cabin space

Tunnel removal and the possibility of having up to 3 cabin seats.

## Less noise in the cab

Less than 70 db thanks to the new soundproofing concept.

## Ergonomic cabin layout

Layout of controls and display of ergonomic and adjustable functions according to the operator's needs.

- 10" Interactive display for sweeping function.
- 4.3" display for engine and road circulation functions.
- Armrest with multifunction Joystick.

## Filtering and pressurisation system

System designed to meet the high standards and regulations of the Agriculture sector.

## Simplified daily maintenance

- Hydraulic opening of the Box Door.
- Conveyor washing with hydrant connection.
- Water system draining system.
- 50% faster central brush replacement system.

## Cabin disinfection and sanitisation

The cab can also be sanitised through photocatalytic oxidation.







VERSATILITY

# Adaptable to different sweeping needs

Different ways of using  
the sweeper based on the  
environments or type of  
materials to be collected.



# Adaptive Technology

## A.S.T.

- Possibility of selecting different work programs: STD, ECO, Boost and Leaves.
- Possibility of storing customised work programs by operator, environment or work mode.

## Adjustable Working Speed (A.W.S.)

Possibility of adjusting the maximum working speed.

## Memory

Possibility of putting the functions in Stand-by and resume work with the same configuration.

## Adaptive sweeping width

Ability of the side brushes to open and close according to the steering angle.

## 4 and 2 steering wheel system

- Possibility of selecting the most comfortable transfer mode.
- 4 steering wheels for maximum manoeuvrability.
- 2 steering wheels for greater comfort and driving precision/ simplicity.
- Automatic alignment of the wheels.





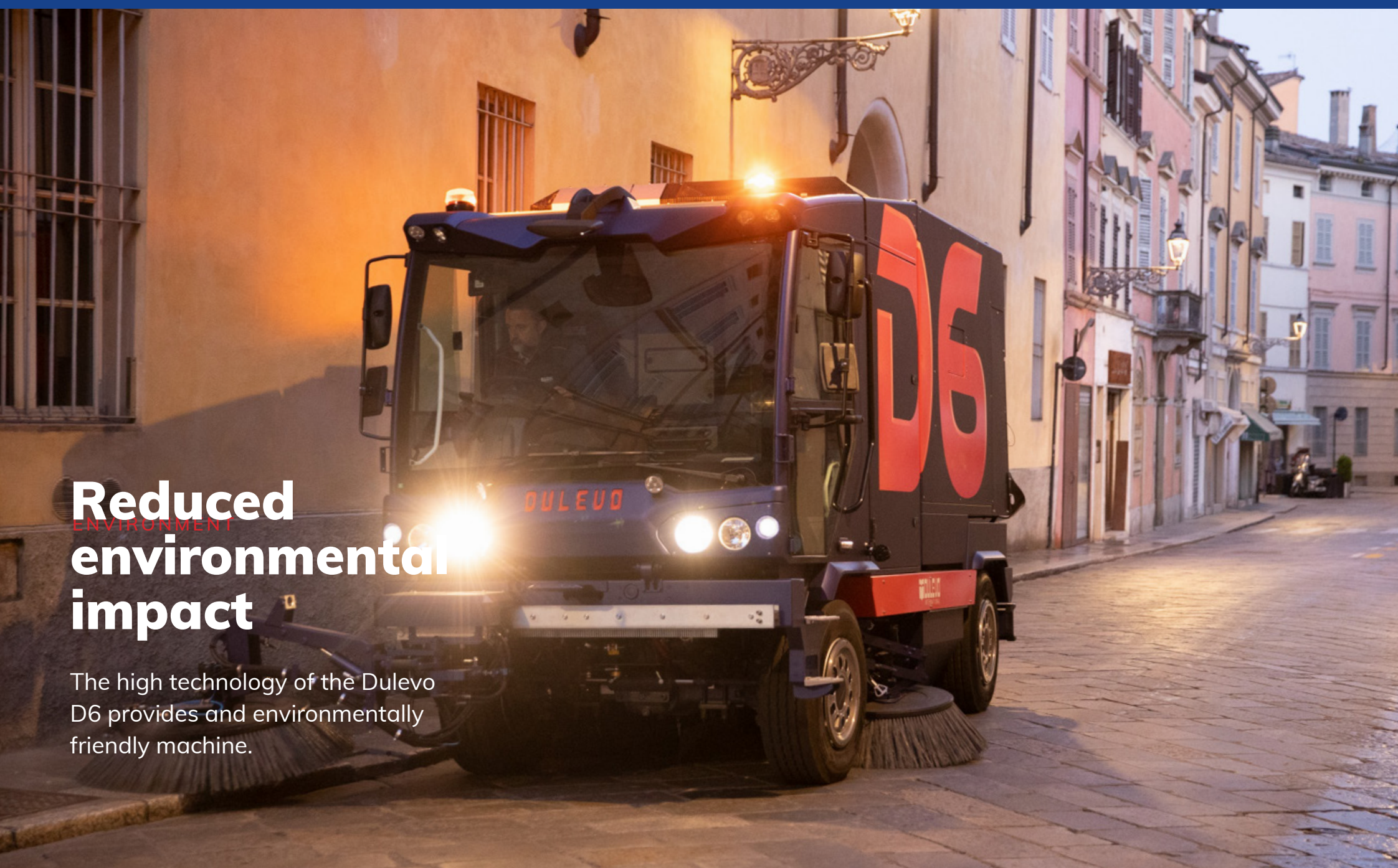

# Reduced environmental impact

The high technology of the Dulevo D6 provides an environmentally friendly machine.



# Reduced environmental impact

## Low sound power

Less than 100 db thanks to Load Sensing.

## Reduced water consumption

The mechanical suction system allows the machine to work, drastically reducing water consumption.

## Low fine dust emissions

EN15429 certified filtration system. Possibility to mount Gore filters to increase performance.

## Low fine dust emissions

Euro 6C engine. The engine complies with the most recent European emission regulations.

## Low fuel consumption

Electronic transmission and high sweeping speed.







# Technical data sheet

<b>Technical data</b>		<b>D6</b>
Sweeping width		
- With central brush	mm	1300
- With central brush and side brushes	mm	2800
- With central, side brushes and third brush	mm	3600
Container volume	m <sup>3</sup>	6,2
Dumping height (OPT.)	mm	1150 (2400)
Seats in the cabin (OPT.)	n°	2 (3)
Cleaning performance	m <sup>2</sup> /h	108.000
Maximum speed	Km/h	25 - 40 - 50
Steering diameter Kerb to Kerb	mm	9675
PM Certification		PM 2,5/PM10****
Engine Brand		FPT industrial (Iveco)
Engine emissions		EURO 6 C
Fuel		Diesel

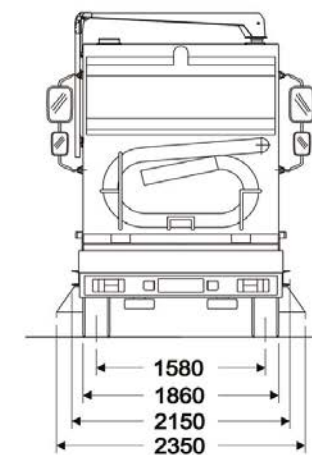
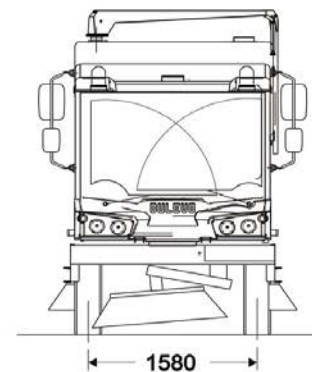
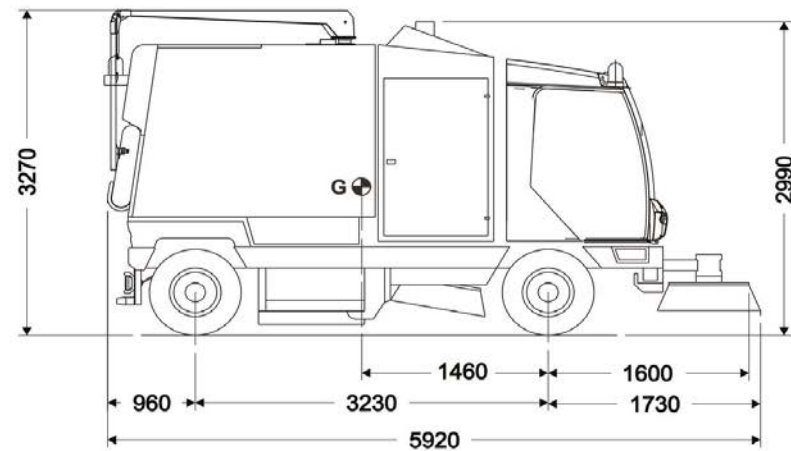





COD. F034F10000 Ed. 00-2021 © (copyright) 2014 Dulevo International S.p.a

Specifications are not binding for our company and subject to change at any time without notice

Dulevo International S.p.A.  
Via Giovannino Guareschi, 1  
43012 Fontanellato (PR) Italia  
Tel: +39-0521-827711  
Fax: +39-0521-827795  
**[www.dulevo.com](http://www.dulevo.com)**