



6000
Street sweeper

 **DULEVO**
FAYAT GROUP



Design, innovative and robust construction, effective solutions for all applications and the exclusive mechanical-suction-filtering system makes the Dulevo 6000 the perfect work tool for all seasons - anywhere and at any time - regardless of high or low temperatures, sun, rain or snow.



Up to date technology and top-quality components ensure the high standards demanded by the market – a guaranty of longevity.

Thanks to the Dulevo patented mechanical-suction-filtering system, the Dulevo 6000 sweeper has a performance three times higher than any other traditional sweeper. The collection is mechanical and is facilitated by the side brushes, which convey the debris toward the centre of the machine, where the cylindrical central brush then sends it at a high speed onto a vertical conveyor. The debris is loaded through the upper part in the refuse container, this way optimizing the loading capacity of the machine. The dust raised by the cylindrical central brush is sucked and kept in the refuse container thanks to the depression in the container itself created by two high-range and high-prevalence suction fans. The peculiar fabric filtering system retains even the thinnest particulates and completes the sweeping cycle, guaranteeing the reintroduction in the environment of clean air only.





In cooperation with Gore® Dulevo developed the only worldwide existing full fine dust filtration sweeper. This mechanical-suctionfiltration system grants with the exclusive application of the Gore® technology a total abatement of PM10 particles.

Further benefits of the filter technology are:

- No maintenance
- Self cleaning effect
- Highest proofed absorbing of PM10 / PM5 / PM2,5 / PM 1
- Granted constant & durable filtering
- 35 % higher airflow
- Resistance against water, oil, fats, chemical agents, etc

GORE dust filters installed in the industrial sweeper have 5 YEARS warranty.





Operators comfort and ergonomics are our priority together with application specifications. Effective axle suspensions and ideal weight distribution insure a balanced and safe drive ability. The powerful drive transmission guarantees the use in difficult conditions and on slopes too. Four-wheel, synchronised and hydraulic steering makes this road sweeper highly manoeuvrable, even in the most complex situations.





The **Dulevo 6000 Combi** version combine the functions of sweeping and washing / sanitizing. The machine, with a single operator and directly from the cabin, can sweep and wash / sanitize at the same time. The high pressure lance with facilitating arm allows a second operator to wash and sanitize pavements even in the presence of parked cars.

Technical data

		Combi
Washing width	mm	2100
Water tank capacity	mm	1050 ÷ 1150



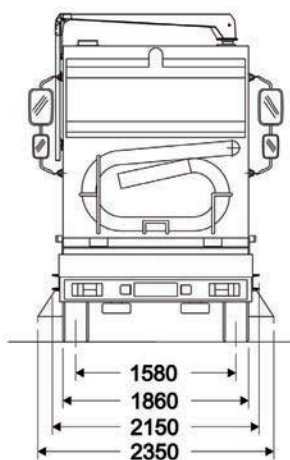
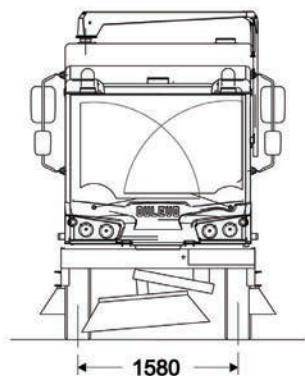
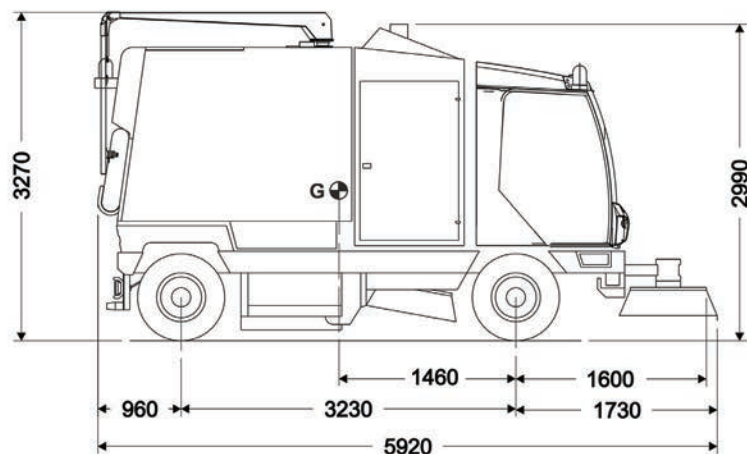

6000

Technical data

		6000
Sweeping width		
- With central brush	mm	1300
- With central brush and side brushes	mm	2600
- With central, side brushes and third brush	mm	3500
Container volume	m ³	6,2
Dumping height (OPT.)	mm	1150 (2400)
Seats in the cabin	n°	2 (3)
Cleaning performance	m ² /h	105.000
Steering diameter -kerb to kerb	mm	9360
Maximum speed	Km/h	25 - 42
PM Certification		PM 2,5/PM10****
Engine Brand		FPT industrial (Iveco)
Engine emissions		Stage IIIA (EU4)
Fuel		Diesel



COD. F031CI0000 Ed. 01-2021 © (copyright) 2014 Dulevo International S.p.a.

Specifications are not binding for our company and subject to change at any time without notice.

Dulevo International S.p.A.
Via Giovannino Guareschi, 1
43012 Fontanellato (PR) Italia
Tel: +39-0521-827711
Fax: +39-0521-827795
www.dulevo.com

